

This Page Is Inserted by IFW Operations
and is not a part of the Official Record

BEST AVAILABLE IMAGES

Defective images within this document are accurate representations of the original documents submitted by the applicant.

Defects in the images may include (but are not limited to):

- BLACK BORDERS
- TEXT CUT OFF AT TOP, BOTTOM OR SIDES
- FADED TEXT
- ILLEGIBLE TEXT
- SKEWED/SLANTED IMAGES
- COLORED PHOTOS
- BLACK OR VERY BLACK AND WHITE DARK PHOTOS
- GRAY SCALE DOCUMENTS

IMAGES ARE BEST AVAILABLE COPY.

**As rescanning documents *will not* correct images,
please do not report the images to the
Image Problem Mailbox.**

(21) Application No 9308009.1

(22) Date of Filing 19.04.1993

(71) Applicant(s)
Paul Albert Thodiyil
The Doctors' Mess, Joyce Green Hospital,
DARTFORD, Kent, DA1 5PL, United Kingdom

(72) Inventor(s)
Paul Albert Thodiyil

(74) Agent and/or Address for Service
Langner Parry
High Holborn House, 52-54 High Holborn, LONDON,
WC1V 6RR, United Kingdom

(51) INT CL⁵
A61F 2/46, B06B 1/00

(52) UK CL (Edition M)
A5R RAT
H4J JGE J31C J31T J31V
U1S S1037

(56) Documents Cited
WO 92/22259 A1 WO 91/11965 A1 WO 90/04953 A1
US 5019083 A US 4248232 A

(58) Field of Search
UK CL (Edition M) A5R RAP RAT
INT CL⁵ A61B 19/00, A61F 2/46
ONLINE DATABASES: WPI, MEDLINE

(54) Ultrasound apparatus and method for securing or removing a prosthesis

(57) A method of securing a prosthesis to a bone includes inserting cement into a cavity formed in the bone, locating the prosthesis in the cemented cavity and, before the cement sets, applying ultrasound to the cement through the prosthesis at a frequency and for a time to substantially eliminate folds and inclusions in the cement. The ultrasonic frequency may be c. 20KHz. Alternatively, a cemented prosthesis may be removed by applying ultrasound thereto firstly at a frequency to cause fatigue fracture of the cement-bone and cement-prosthesis bonds, then at a frequency to cause cavitation in the interface and finally at a frequency to cause thermal softening of the cement. The ultrasound apparatus used may include a magnetostriction transducer 20 connected to a conductive body 10 which has adjustable jaws 12 for gripping the prosthesis 4, and means for controlling the resonant frequency of the transducer.

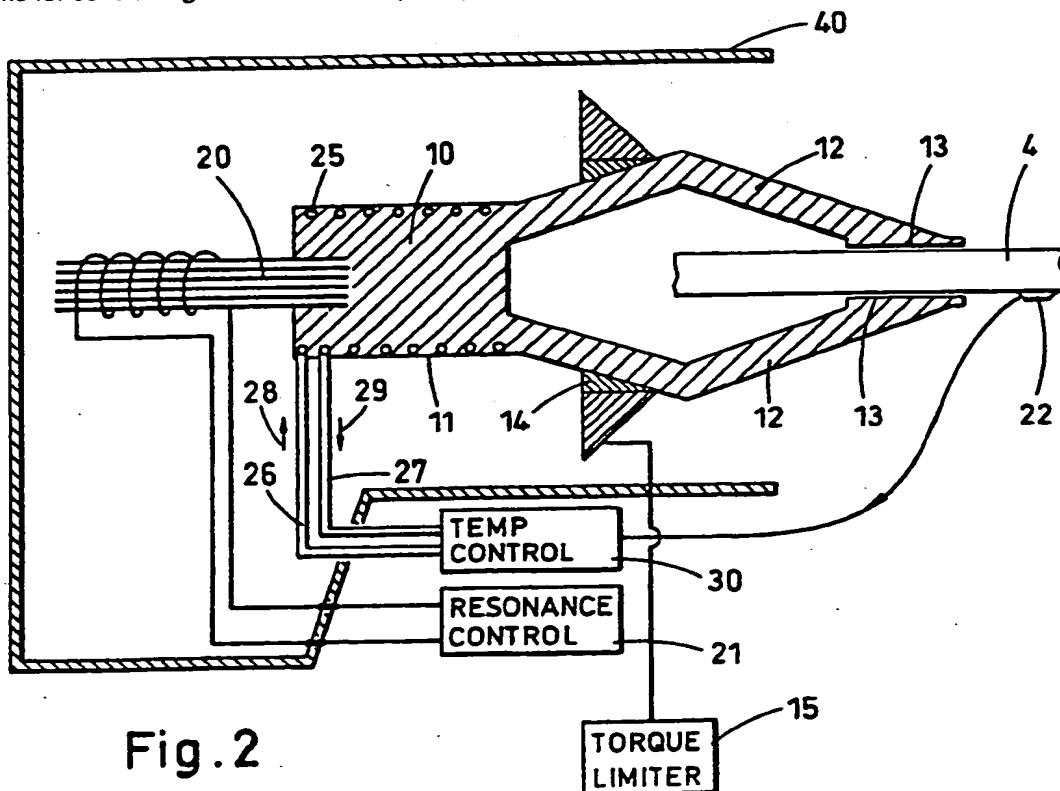

Fig. 2

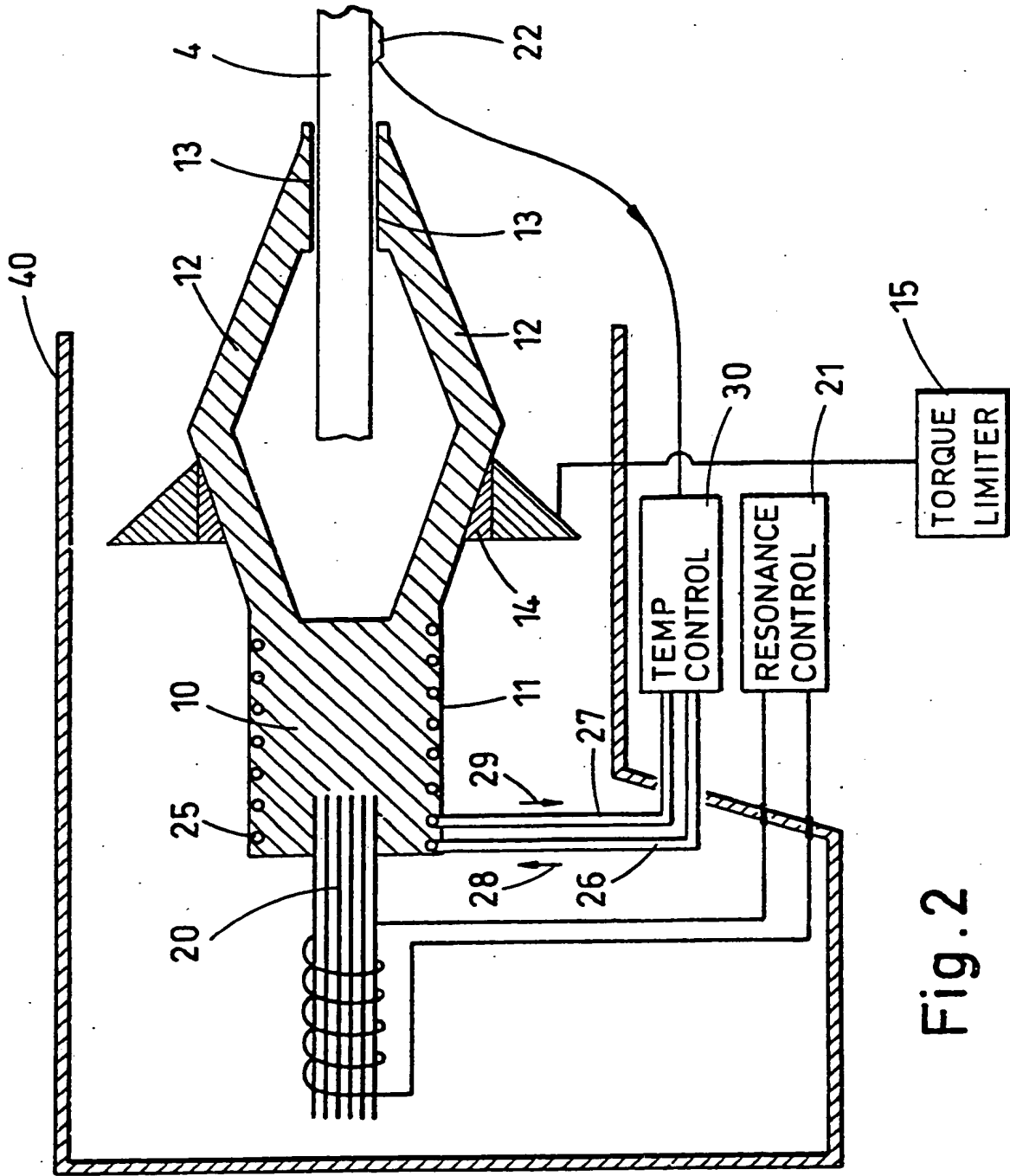

Fig. 2

rough interior of the femur is produced. The process of setting takes about fifteen minutes from the time that mixing starts to final hardening.

It has, unfortunately, been found that mixing the cement to a dough-like consistency leaves cavities and inclusions in the cement. Although PMMA has been shown to have good load-carrying capabilities in compression, it is weak in tension, sheer, and fatigue resistance resulting in fracture of the cement and causing loosening of the prosthesis. As described by Wixson, Lautenshlager, and Novak in The Journal of Arthroplasty, Volume 2, No. 2, June 1987, at pages 141 - 149, there have been numerous attempts to strengthen the cement by adding various fillers, such as glass or carbon fibres. These methods tend to clog the opening of the pores into the trabecula bone and may result in an abnormal distribution of the fibres and local alteration in the material properties of the cement-bone interface. In this paper it is stated that none of the reinforced cements has been released by the Food and Drug Administration for general use and they are not used clinically.

So as to overcome the problem of cement-bone breakdown, Wixson et al teach that in conventional mixing of the cement, the mixing process traps small bubbles of air and as stirring of the dough-like mixture commences, the cement forms into two discrete masses or lumps which coalesce, trapping more air bubbles of a larger diameter in the mixture. To overcome this problem, Wixson et al discloses cooling the components to be mixed in an ice water bath and mixing the components in a vacuum in the range 500 - 550mmHg.

Despite the attempts at improving the fixation of a prosthesis to a bone, it is often necessary to conduct a revision process whereby an existing prosthesis has to be removed and a new prosthesis fitted. It is difficult to remove a prosthesis, and in particular the cement cast; the

applying ultrasound to the cement through the prosthesis at a frequency and for a time to substantially eliminate folds and inclusions in the cement.

Preferably, the cement is a cold-curing cement such as polymethylmethacrylate (PMMA).

Preferably, the ultrasonic frequency is approximately 20KHz.

According to a second aspect of this invention there is provided a method of removing a prosthesis cemented into a bone including the steps of

(a) applying an ultrasonic frequency to the prosthesis at such a frequency to cause fatigue fracture of bonding between the bone and cement, and between prosthesis and cement,

(b) applying an ultrasonic frequency to the prosthesis to cause cavitation by negative (tensile) pressure wave front advancing through water found in the interface between the prosthesis, cement, and bone,

(c) applying an ultrasonic frequency to the prosthesis to cause thermal softening of the cement, and

(d) removing the prosthesis.

Preferably, the frequency used for steps (a) and (c) is approximately 500KHz and the frequency for step (b) is approximately 20KHz.

Preferably, after breaking the bond between the prosthesis and cement, the prosthesis is cooled to a temperature to shrink the prosthesis with respect to the bone without damaging living tissue to assist removal of the prosthesis.

According to a third aspect of this invention there is provided an ultrasound apparatus including an ultrasonic transducer connected to a conductive body having attachment means for attaching said body to a prosthesis, and controlling means for controlling the resonant frequency of said transducer.

The attachment means comprise a pair of adjustable

parts.

Referring to Figure 1, a femur shaft 1 is hollowed out in any known manner, for example as discussed above in the reference, The Journal of Bone and Joint Surgery, to form a cavity 2 which is filled with polymethylmethacrylate (PMMA) cement 3. A hip joint metallic prosthesis 4 known per se having a stem 5, femoral head 6 and ball 7 is mounted in the cemented cavity 2.

The apparatus of the invention is shown in Figure 2 and has an ultrasonically conductive body 10 formed, for example, of titanium. The body has a cylindrical end portion 11 formed, for example integrally, with two or more jaws 12. In the preferred embodiment the body has four equi-circumferentially spaced adjustable jaws 12, the greater the number of jaws, the better being the propagation of ultrasonic frequency from the body 10 to a prosthesis 4. In this respect, the jaws 12 have faces 13 for securement about the prosthesis 4. A pneumatic clamp 14 is provided to securely attach the jaws about the prosthesis 4. The pneumatic jaws 14 may be connected to a torque limiting device 15 to ensure that the jaws do not clamp too tightly on the prosthesis.

An ultrasonic transducer 20, for example a magnetostriction device, is connected to the end 11 of the body 10 and the ultrasonic transducer 20 is connected to a resonance frequency controller 21. The resonance frequency controller 21 is connected with a resonance sensor (not shown) that is integrated within the ultrasound source 20 for adjusting the resonant frequency for maximum efficiency.

The end 11 of the body 10 is integrally formed with a coil 25 for transferring cooling liquid air to the body 10. The coil 25 is connected to an inlet pipe 26 and an outlet pipe 27, the direction of flows of air being as indicated by arrow headed lines 28 and 29. The inlet and outlet pipes 27 are connected to a temperature controller 30, the

It is possible that the prosthesis can then be withdrawn from the bone, but the present invention preferably provides thermal shrinkage of the prosthesis to more readily facilitate removal of the prosthesis from the bone. In this respect, cooled air is supplied through the coil 25 to the body 10 and thence through conduction to the jaws 12 and to the prosthesis. The amount of cooling is down to a level such that the metal prosthesis shrinks but is not so low that the bone or other living tissue is damaged. The temperature of the prosthesis 4 is detected by the heat detector located within the sensor device 22 which supplies signals to the temperature controller 30.

By the use of the apparatus of this invention, the interface bonding between prosthesis/cement and cement/bone is disrupted by the combination of fatigue fracturing, cavitation effects and thermal softening of the visco-elastic cement material (PMMA). Fracturing these bonds facilitates removal of the prosthesis and of the cement. Removal of the prosthesis in revision surgery is further enhanced by shrinking the prosthesis through cooling.

transducer connected to a conductive body having attachment means for attaching said body to a prosthesis, and controlling means for controlling the resonant frequency of said transducer.

5 8. An ultrasound apparatus as claimed in claim 7 wherein the attachment means comprise a pair of adjustable jaws for gripping the prosthesis or four equi-circumferentially spaced adjustable jaws for gripping the prosthesis.

9. An ultrasound apparatus as claimed in claim 8 wherein
10 an adjustable clamp is provided for enabling the prosthesis to be securely gripped by the jaws.

10. An ultrasound apparatus as claimed in claim 9 wherein said clamp is a pneumatic clamp connected to a source of compressed air.

15 11. An ultrasound apparatus as claimed in claim 10 wherein a torque limiting device is provided to limit the grip provided by said jaws.

12. An ultrasound apparatus as claimed in any of claims 7 to 11 wherein resonance sensor means is provided for
20 detecting the resonant frequency of the ultrasonic transducer, said resonance sensor means being connected to said controlling means, whereby in dependence upon the output of said resonance sensor means, said controlling means adjusts the resonant frequency for maximum
25 efficiency.

13. An ultrasound apparatus as claimed in any of claims 7 to 12 wherein said conductive body is provided with cooling means whereby said prosthesis may be shrunk to assist removal in revision surgery.

30 14. An ultrasound apparatus as claimed in claim 13 wherein said cooling means is integrally formed with said body and conveniently is supplied from a source of cooled or liquid air.

35 15. An ultrasound apparatus as claimed in claim 12 wherein the sensor means includes a heat detector for detecting the temperature of the prosthesis, which said heat detector is

Relevant Technical Fields

- (i) UK Cl (Ed.M) A5R (RAP, RAT)
- (ii) Int Cl (Ed.5) A61B 19/00, A61F 2/46

Search Examiner
L V THOMAS

Date of completion of Search
21 JULY 1994

Databases (see below)

(i) UK Patent Office collections of GB, EP, WO and US patent specifications.

(ii) ONLINE DATABASES: WPI, MEDLINE

Documents considered relevant following a search in respect of Claims :-
1-6, 16, 17

Categories of documents

- X:** Document indicating lack of novelty or of inventive step.
- Y:** Document indicating lack of inventive step if combined with one or more other documents of the same category.
- A:** Document indicating technological background and/or state of the art.
- P:** Document published on or after the declared priority date but before the filing date of the present application.
- E:** Patent document published on or after, but with priority date earlier than, the filing date of the present application.
- &:** Member of the same patent family; corresponding document.

Category	Identity of document and relevant passages	Relevant to claim(s)
X	WO 92/22259 A1 (ADVANCED OSSEOUX TECH) see line 16 page 14-line 13, page 15 and lines 7-21 page 32	4
X	WO 91/11965 A1 (ADVANCED OSSEOUX TECH) see line 35 page 4-line 12 page 5 and lines 4-21 page 8	4
X	WO 90/04953 A1 (NILSSON) see lines 10-35 page 3	1,2
X	US 5019083 (KLAPPER ET AL) see lines 10-63 column 4 and line 54 column 5 line 3 column 6	4
X	US 4248232 (ENGDBRECHT ET AL) see lines 10-45 column 4	4

Databases: The UK Patent Office database comprises classified collections of GB, EP, WO and US patent specifications as outlined periodically in the Official Journal (Patents). The on-line databases considered for search are also listed periodically in the Official Journal (Patents).